

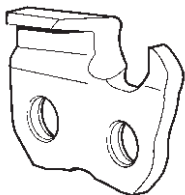



MICRO CHISEL®



Kickback Reducing Features 	End View 	Use 
--	--	---

Not a Low-kickback Chain

Chain Type	Gauge
25AP	.050"

FILING

① DEPTH-GAUGE SETTING

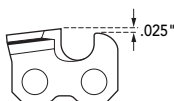

② TOP-PLATE CUTTING ANGLE

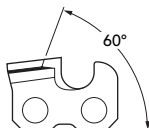

③ SIDE-PLATE ANGLE

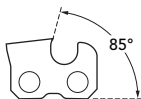

④ TOP-PLATE FILING ANGLE

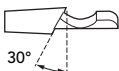

⑤ FILE-GUIDE ANGLE

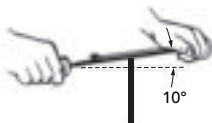

TOOLS FOR FILING

Part No.	Description
70504	5/32" Round File (12-Pack)
37534	5/32" Assembled File Guide
22290	.025" Depth-gauge Tool
OR534-18	1/8" Grinding Wheel, 5-3/4" Dia.
OR4125-18	1/8" Grinding Wheel, 4-1/8" Dia.

Chains on this page are intended for use with saws up to 2.3 cu. in. displacement (38 cc), and bars up to 16 in. length (41 cm).

36 Micro Chisel® .325"

MICRO CHISEL®

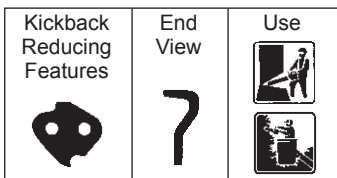
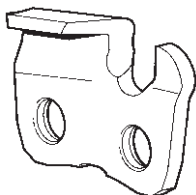

Not a Low-kickback Chain

Low-vibration Chain

Chain Type	Gauge
20BP	.050"
21BP	.058"
22BP	.063"

FILING

① DEPTH-GAUGE SETTING

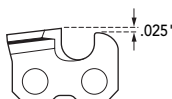

② TOP-PLATE CUTTING ANGLE

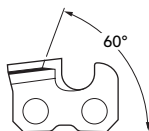

③ SIDE-PLATE ANGLE



④ TOP-PLATE FILING ANGLE

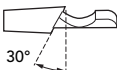

⑤ FILE-GUIDE ANGLE

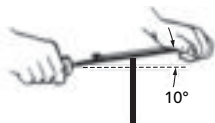

TOOLS FOR FILING

Part No.	Description
70503	3/16" Round File (12-Pack)
31690	3/16" Assembled File Guide
31941	.025" Drop-Center Depth-gauge Tool
OR534-316	3/16" Grinding Wheel, 5-3/4" Dia.
OR4125-316	3/16" Grinding Wheel, 4-1/8" Dia.

Chains on this page are intended for use with saws up to 3.5 cu. in. displacement (58 cc), and bars up to 20 in. length (50 cm).

CHISEL®

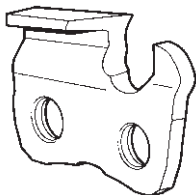

Kickback Reducing Features 	End View 	Use
---------------------------------------	---------------------	----------------

Not a Low-kickback Chain

Low-vibration Chain

Chain Type	Gauge
20LP, M20LP	.050"
21LP, M21LP	.058"
22LP, M22LP	.063"

FILING

① DEPTH-GAUGE SETTING

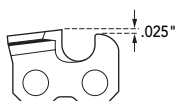

② TOP-PLATE CUTTING ANGLE

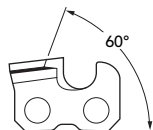

③ SIDE-PLATE ANGLE



④ TOP-PLATE FILING ANGLE

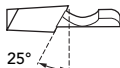

⑤ FILE-GUIDE ANGLE

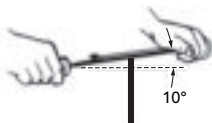

TOOLS FOR FILING



Part No.	Description
70503	3/16" Round File (12-Pack)
31690	3/16" Assembled File Guide
31941	.025" Drop-Center Depth-gauge Tool
OR534-316	3/16" Grinding Wheel, 5-3/4" Dia.
OR4125-316	3/16" Grinding Wheel, 4-1/8" Dia.

Chains on this page are intended for use with saws up to 3.5 cu. in. displacement (58 cc), and bars up to 20 in. length (50 cm).

38 Super Guard® .325"

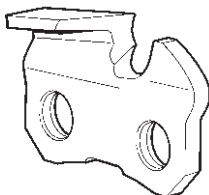
CHISEL®



Kickback Reducing Features 	End View 	Use 
--	--	---

Not a Low-kickback Chain

No Bumper Tie Straps

Low-vibration Chain

Chain Type	Gauge
33LG	.050"
34LG	.058"
35LG	.063"

FILING

① DEPTH-GAUGE SETTING

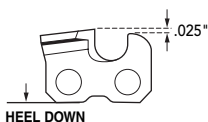

② TOP-PLATE CUTTING ANGLE

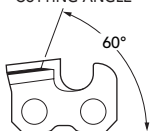

③ SIDE-PLATE ANGLE

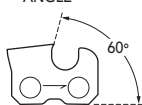

④ TOP-PLATE FILING ANGLE

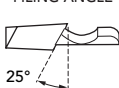

⑤ FILE-GUIDE ANGLE

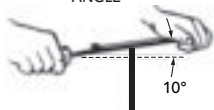

TOOLS FOR FILING

Part No.	Description
70511	4.5 mm Round File (12-Pack)
31692	4.5 mm Assembled File Guide
31941	.025" Drop-Center Depth-gauge Tool
OR534-18	1/8" Grinding Wheel, 5-3/4" Dia.
OR4125-18	1/8" Grinding Wheel, 4-1/8" Dia.

Chains on this page are intended for use with saws up to 3.8 cu. in. displacement (62 cc), and bars up to 20 in. length (50 cm).

CHISEL®

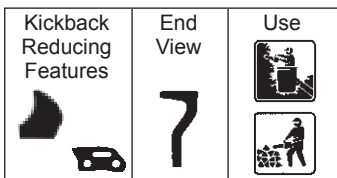
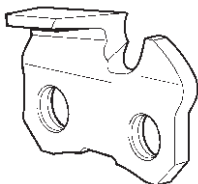

A Low-kickback Chain **With Bumper Tie Straps**

Chain Type	Gauge
33SL	.050"
34SL	.058"
35SL	.063"

Low-vibration Chain

FILING

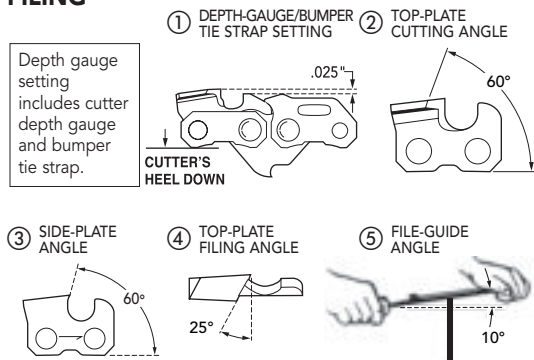





TOOLS FOR FILING

Part No.	Description
70511	4.5 mm Round File (12-Pack)
31692	4.5 mm Assembled File Guide
31941	.025" Drop-Center Depth-gauge Tool
OR534-18	1/8" Grinding Wheel, 5-3/4" Dia.
OR4125-18	1/8" Grinding Wheel, 4-1/8" Dia.

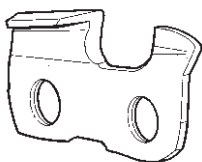
Chains on this page are intended for use with saws up to 3.5 cu. in. displacement (58 cc), and bars up to 20 in. length (50 cm).

MICRO CHISEL®



Kickback Reducing Features 	End View 	Use 
--	--	---

A Low-kickback Chain

Low-vibration Chain

Narrow-kerf Chain

Chain Type	Gauge
95VP	.050"

FILING

① DEPTH-GAUGE SETTING

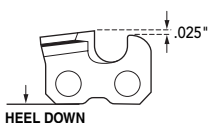

② TOP-PLATE CUTTING ANGLE

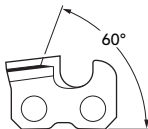

③ SIDE-PLATE ANGLE

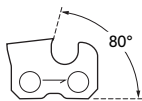

④ TOP-PLATE FILING ANGLE

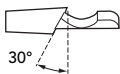

⑤ FILE-GUIDE ANGLE

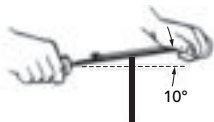

TOOLS FOR FILING

Part No.	Description
70503	3/16" Round File (12-Pack)
31690	3/16" Assembled File Guide
31941	.025" Drop-Center Depth-gauge Tool
OR534-316	3/16" Grinding Wheel, 5-3/4" Dia.
OR4125-316	3/16" Grinding Wheel, 4-1/8" Dia.

Chains on this page are intended for use with saws up to 2.8 cu. in. displacement (45 cc), and bars up to 18 in. length (45 cm).

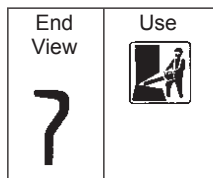
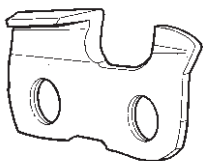
MICRO CHISEL®

Not a Low-kickback Chain

Narrow-kerf Chain

Low-vibration Chain

Chain Type	Gauge
95R (Micro-Lite™)	.050"

FILING

① DEPTH-GAUGE SETTING

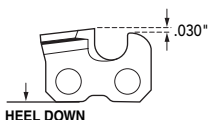

② TOP-PLATE CUTTING ANGLE

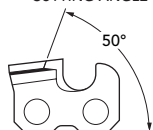

③ SIDE-PLATE ANGLE



④ TOP-PLATE FILING ANGLE

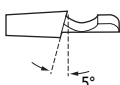

⑤ FILE-GUIDE ANGLE

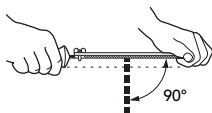
**TOOLS FOR FILING**

Part No.	Description
70503	3/16" Round File (12-Pack)
22291	.030" Depth-gauge Tool
OR534-316	3/16" Grinding Wheel, 5-3/4" Dia.
OR4125-316	3/16" Grinding Wheel, 4-1/8" Dia.

Ripping chains feature a special grind for use in ripping cuts only. Do not use these chains for any type of cutting other than ripping.